

Power Handling Capability of Electromechanical Switches

Introduction

RF/microwave electromechanical switches are used in a wide variety of signal routing applications for test and measurement systems. Typical applications for electromechanical switches include: selection of multiple signal sources to one output, selection of multiple input signals to one measurement instrument, transfer switching to insert or remove a device in a signal path and matrix switching of multiple inputs and outputs. Keysight Technologies electro-mechanical switches provide broadband performance with low insertion loss, high isolation, and exceptional repeatability throughout a long operating life. One important parameter for electromechanical switches that is often misunderstood is power handling. The ability of a switch to handle power is very dependant on the design and materials used in a switch. In the datasheet, there are different power-handling ratings for the switches such as hot switching, cold switching, average power and peak power. Understanding these different terms will help you avoid catastrophic failure of the switch or instruments.



Hot Switching

Hot switching occurs when RF/microwave power is present at the ports of the switch at the time of the switching. It causes the most stress on internal contacts, and can lead to premature failure. Table 1 shows an example of a power handling specification. In the table, the hot switching specification is shown as “Switching: 1 W CW” which indicates that the switch can be hotswitched at 1 W CW.

Table 1. Power handling specification

Power handling specification	
Maximum power rating	1 watt average into 50 Ω internal loads
Switching	1 W CW
Non-switching	50 W Pk (not to exceed 1 W average)

When a circuit carrying power is opened, there is always some arcing between the contacts if the voltage and current are above the minimum spark voltage and current. This is similar to an electrical arc. When two electrodes carrying an electric current are drawn apart, the strong forces will draw electrons from one electrode to the other, resulting in an arc. This arcing causes degradation of the switch contacts by leaving deposits on them and burning them.

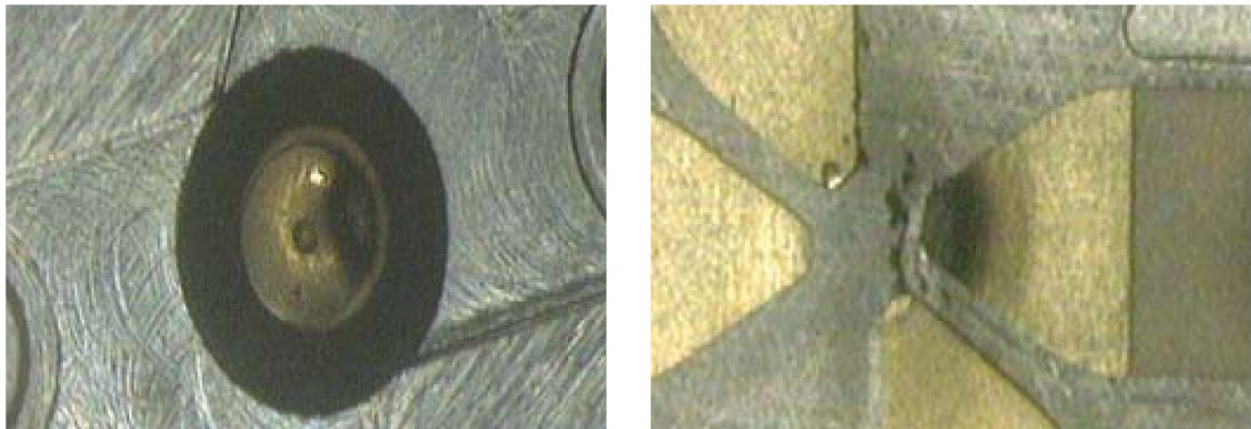

Figure 1. Deposits and burn marks on the contact surface

The worst case for arcing is at DC voltages where the voltage is constant and will sustain an arc longer. At AC voltages, the voltage passes through zero twice each cycle, this quick cycling is not constant so the arc will often extinguish. By referring to the specifications in Table 1, you can be sure to select the right power level. The specified 1 W CW causes minimal arcing effect for hot switching. When the power level goes higher, the stronger electromagnetic field will cause more arcing, and lead to premature failure of the switch contacts.

Cold Switching

Cold switching occurs when the signal power is removed before switching. Cold switching results in lower contact stress and longer life. It is recommended in situations where the signal power can be removed before switching.

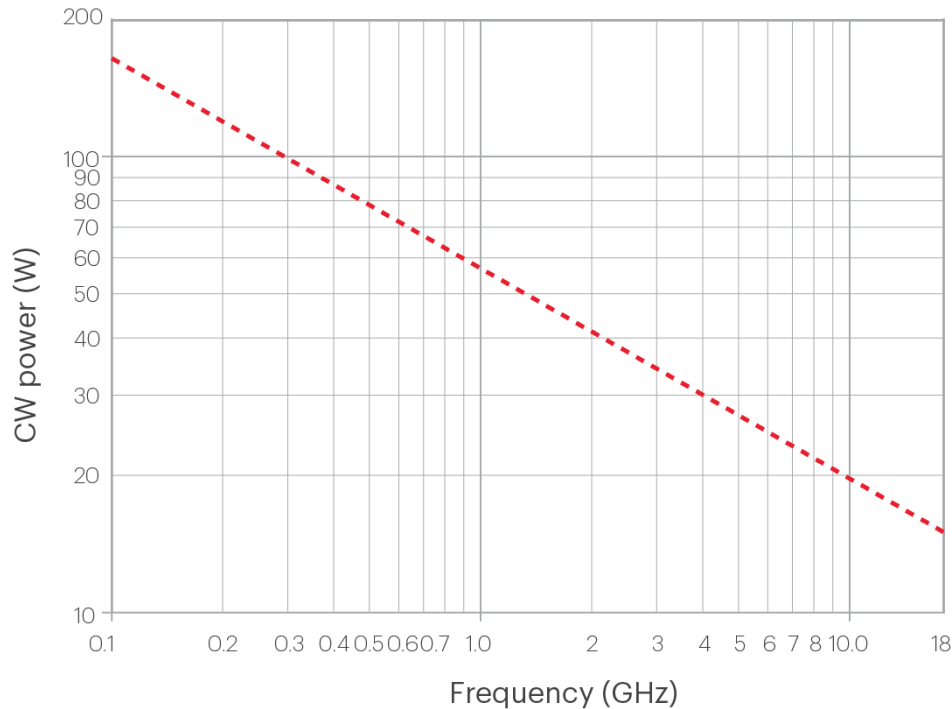

Figure 2. Power rating for cold switching

Cold switching is the power handling rating which users normally refer to. Figure 2 shows the supplementary characteristic for cold switching at 75 °C. This refers to the ambient temperature of the environment where the switch is in operation. When the ambient temperature gets higher, the heating effect within the switch will increase and will reduce the maximum power handling capability of the switch. The power handling of Keysight's switches are specified at an operating temperature of 75 °C instead of 25 °C. This is due to the fact that 25 °C might not reflect the realistic operating condition of the switch. When used in an enclosed switch matrix, the typical operating temperature goes up to approximately 40 °C. This means that the actual power rating will be lower than the specified power rating at 25 °C.

Cold switching applies when one RF port is making through connection with another RF port. For through paths, there is localized heating of the discontinuities at the point of contact where the constriction resistance and the current flow produce heat. When high temperatures are confined in a small area, the effects can accumulate and produce early failures including plating separation, burning, metal transfer, etc.

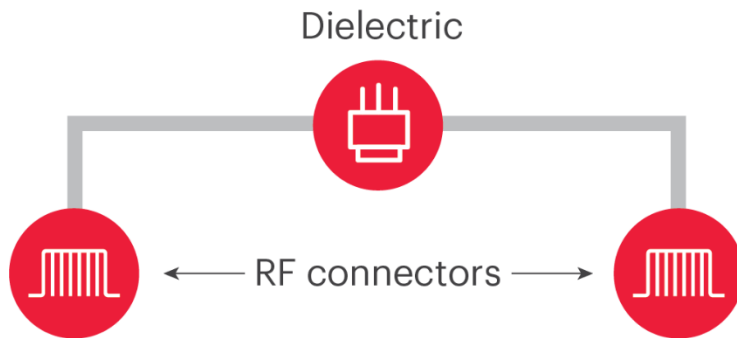

Figure 3. Illustration of RF structure

Cold switching power rating is limited by the dielectric breakdown of the switch, along the conductors. The dielectric property of the material provides pressure for the contact jumper to mate with the RF connector pins (refer to Figure 3). As the contact heats up from skin effect and resistive losses, the heat is transferred to the dielectric. When the temperature gets higher, the dielectric deforms. The pressure applied by the RF contact will decrease and become uneven leading to problems of repeatability. Ultimately, the switch will fail due to improper contact force, or dielectric breakdown. The effect of dielectric breakdown increases with frequency, but is non-uniform due to electric field variations caused by impedance discontinuities.

Internal terminations: average and peak power

High CW power will have heating effects. The power handling capability of the thin film terminations in terminated switches are limited by the amount of heat they are able to sink away. If the average power exceeds this value, the terminations will be heated beyond their tolerance level. The resistor network becomes oxidized resulting in property and performance variations. Therefore, the average power is specified so that the termination can dissipate the heat indefinitely and still remain within the temperature range of the film's specified resistance. Table 1 shows the power handling specification for one of Keysight's terminated switches. The maximum average power that can be handled by the 50 Ω internal terminations is 1 W.

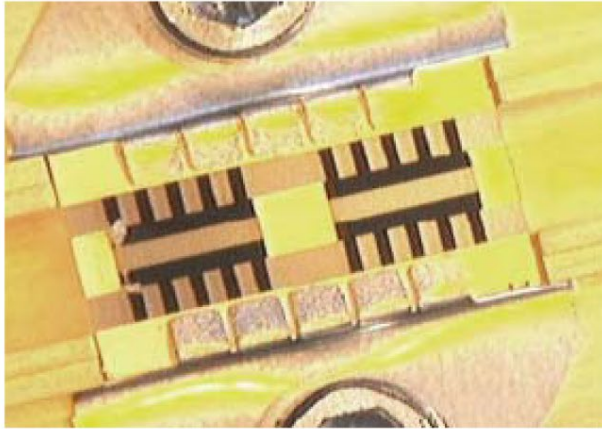

Figure 4. Average power exceeds power limit

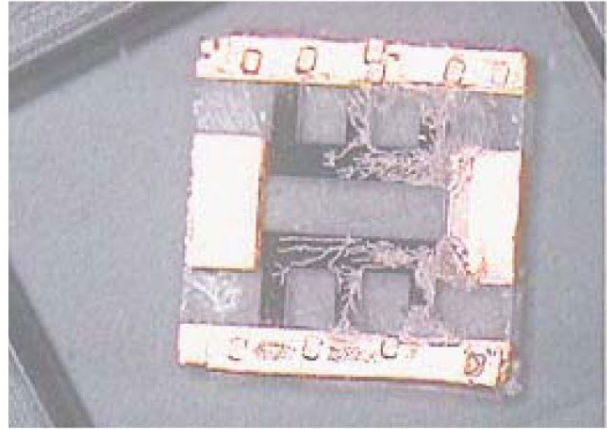

Figure 5. Peak power exceeds power limit

However, in pulse applications the switch can be asked to carry up to 50 W peak, but is not “hot switched”, it will not suffer contact degradation as long as it does not exceed a 1 W average. This instantaneous power must be lower than the instantaneous heat-sinking capability of the resistive terminations as well as the substrate. Too much peak power will cause localized, non-uniform heating of the film, and crack the substrate of the terminations.

In order to prevent damage to the contacts by localized heating of the contact areas, the pulse duration must be limited to allow the heat to dissipate, and adequate time must be allowed before the next pulse is applied. Peak power, pulse duration, and pulse repetition rate must be limited to reduce localized heating, and average power must be limited to allow heat dissipation. Hence, the peak power for non-switching is specified such that rapid, localized heating of the film will not result in the failure of the substrate or the thin film.

Peak power and duty cycle

Average, instantaneous and pulse length are used to determine the duty cycle, that is how long a pulse can be on average power without causing switch damage or failure from overheating.

Average power:
$$p = \frac{1}{T} \int_0^T i(t)v(t) dt$$

If instantaneous power is $p(t)$, Peak power $P_0 = \max (p(t))$

One may define the pulse length as, τ so the ratios are equal $\frac{p_{avg}}{p_0} = \frac{\tau}{T}$

These ratios are called duty cycle.

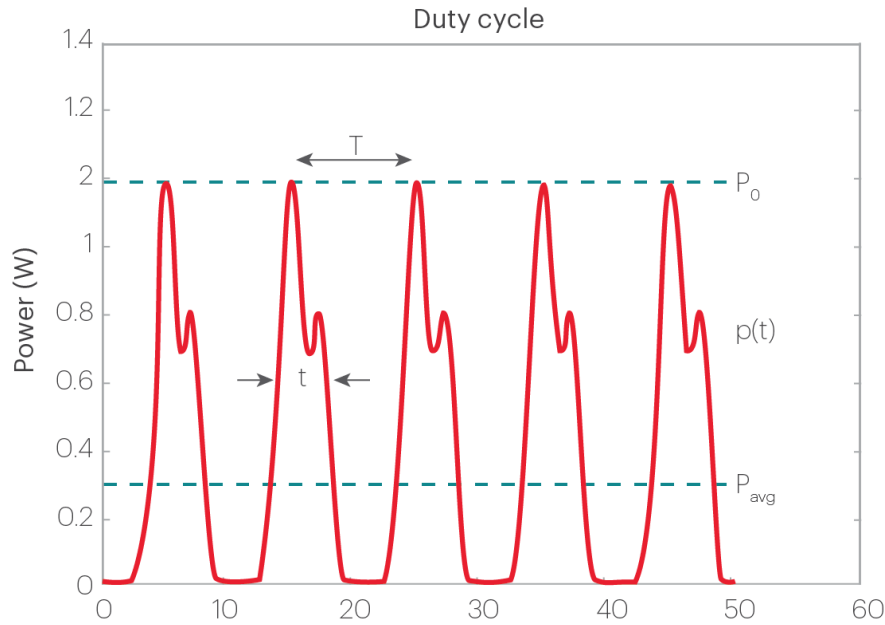

For un-terminated Keysight switches, they are rated at 2 W average or 100 W peak (non-switching) with a 2% duty cycle and pulse width less than 10 μ s.

Power handling test setup

To calculate the maximum power that an electromechanical switch can carry is difficult as many effects are frequency dependent and non-linear, such as skin effects and dielectric losses. There are a lot of assumptions that need to be made which might not provide realistic values. On the other hand, setting up a system to measure the power handling capability of a switch is a costly undertaking that requires specialized high-frequency, high-power test equipment and long periods of testing. Because of this some switch suppliers rely on theoretical calculations, limited testing and data extrapolation instead. Keysight has set up a custom power handling test system to test the switches across the entire operating frequency and several temperature ranges in order to determine the accurate power handling capability of Keysight electromechanical switches. This data will be made available when testing has been completed. Figure 6 shows the setup of the power handling test.

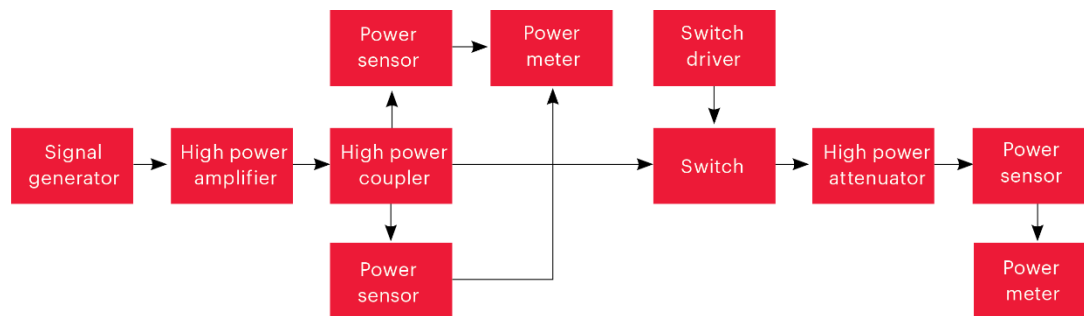

Figure 6. Power handling test setup

When setting up a power handling test, a calibration is performed in the beginning to ensure that the losses of each component, including cables and adapters, are captured so that only the true power value is measured. From the setup, a coupler is connected to the input signal as not only the incident power and transmitted power will be measured, but also the reflected power in order to detect any early failure which might not be seen in insertion loss measurement. To measure different power handling specifications, always remember to set the correct duty cycle for the measurement and to choose the instrument or accessories with correct power ratings.

To determine the power handling capability, the switch needs to be tested under stressful conditions. For cold switching test, it needs to go through a cycling test and also a soak test, which is the worst condition where high power is continuously pumped in so that heat is generated and built up in the switch for an extended period of time. The switch is then cycled again and the process is repeated throughout the life cycle of the switch to determine its capacity.

Conclusion

It is important for users to understand the definition of different types of power handling ratings so that they can select a switch with the proper power handling for their specific application. Also, prior to setting up a system, always verify the operating temperature against the reference temperature of the power specification. If the operating temperature is higher than the reference temperature, the actual power handling capability of the switch will be lower.